

CONDENSED INSTALLATION SPECIFICATIONS
SEWER SERVICE LINE & SEWER SERVICE CONNECTIONS SHALL BE INSTALLED BY SKILLED WORKMEN AT THE COST OF THE CUSTOMER.

USE RUBBER DONUT OR REDUCING COUPLING TO ADAPT VARIOUS MATERIALS & SIZES OF PIPE AS REQUIRED (TYP.)

- NOTES:**
1. ALL PIPE SHALL BE 4" OR 6" SDR35 OR SCH. 40 PVC. SLOPE SHALL BE MIN. 1/4" PER FOOT FOR 4" LINE & 1/8" PER FOOT FOR 6" LINE.
 2. VENT PIPES & CLEANOUTS ARE NOT PERMITTED TO BE LOCATED IN DRIVEWAYS, CART PATHS, WALKWAYS, PATIOS, PORCHES, OR OTHER FINISHED SURFACE AREAS.

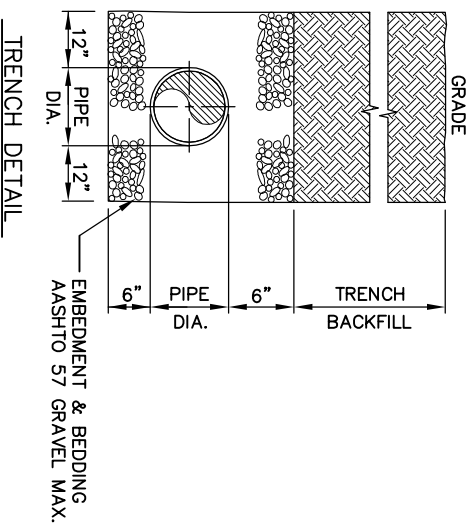
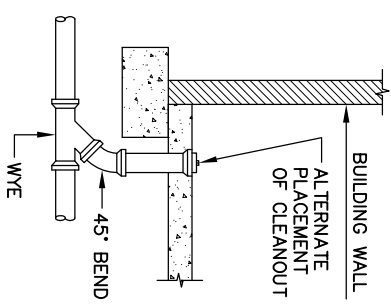

CONNOQUEENESSING BOROUGH
QUAD-CONDO GRAVITY SERVICE CONNECTION TO SANITARY SEWER
STANDARD DETAIL

ORIGINAL NO.	JUNE 2009
REVISIONS	DATE

SCALE: NONE
SHEET NO. **30**